



Mechanical Seal Specification

Determine the best sealing solution for your applications.

Elastomer O-Ring Seals

TIB-500

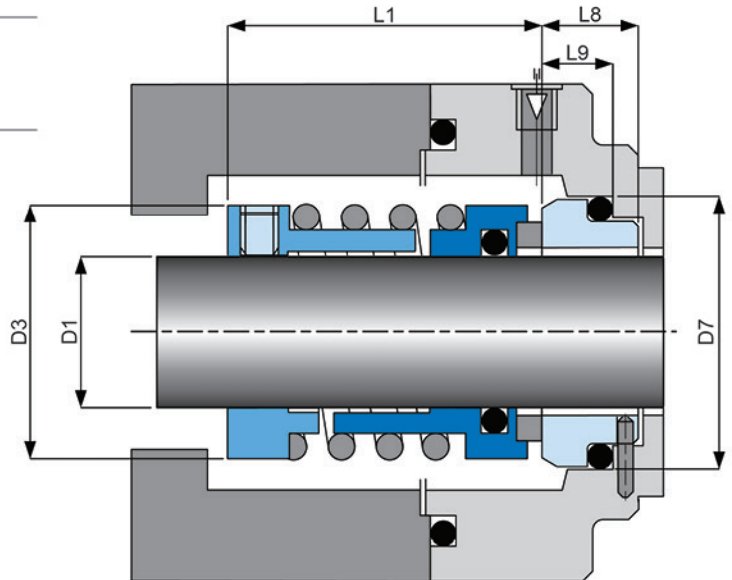

Applications

- For use in pumps, mixers, blenders, agitators, compressors and other rotary shaft equipment.
- For pulp and paper, petrochemical, food processing, wastewater treatment and other demanding applications.

Standard Materials

- Metal Parts : SUS 316
- Spring : SUS 316
- Rotary Face : Silicon Carbide/Tungsten Carbide/Carbon
- Stationary Face : Silicon Carbide/Tungsten Carbide/Carbon
- Secondary Seals : Fluoroelastomer/Nitrile/Ethylene Propylene

*(Other configuration of materials also available on request)

Operating Conditions

- Max. Operating Pressure : 14 kg/cm²*
(For Unbalanced)
- Max. Operating Pressure : 40 kg/cm²*
(For Balanced)
- Temperature Range : -15 to 200 °
- Max. Rubbing Speed : 20 m/s

*(Depend on combination of materials)

Design Features/Benefits

- Positive-drive rotary part is designed for protecting slip of O-ring on shaft.
- Allow easy repair, reduced spares holding, and simple conversion to balanced/unbalanced seal.
- Setting-length of spring can be held in position by build in set-ring.
- Sealing faces are precision lapped to provide effective performance with maximum seal life.



Mechanical Seal Specification

Determine the best sealing solution for your applications.

Dimensional Data (mm.)

D1	D3	D7	L1	L8	L9
18	32	33	38.0	19.5	11.5
20	34	35	38.0	19.5	11.5
22	36	37	38.0	19.5	11.5
24	38	39	38.0	19.5	11.5
25	39	40	38.0	19.5	11.5
28	42	43	40.0	19.5	11.5
30	40	45	40.0	19.5	11.5
33	47	48	40.0	19.5	11.5
35	49	50	40.0	19.5	11.5
38	54	56	45.0	22.0	14.0
40	56	58	45.0	22.0	14.0
43	59	61	50.0	22.0	14.0
45	61	63	50.0	22.0	14.0
48	64	66	55.0	22.0	14.0
50	66	70	55.0	23.0	15.0
53	69	73	58.0	23.0	15.0
55	71	75	58.0	23.0	15.0
58	78	78	58.0	23.0	15.0
60	80	80	60.0	23.0	15.0
65	85	85	62.0	23.0	15.0
68	88	90	62.0	26.0	18.0
70	90	92	65.0	26.0	18.0
75	98	97	65.0	26.0	18.0
80	103	105	70.0	26.2	18.2
85	108	110	70.0	26.2	18.2
90	113	115	70.0	26.2	18.2
95	118	120	75.0	25.2	17.2
100	123	125	75.0	25.2	17.2

* Other sizes are available upon request.